

ESSER

by Honeywell

User Manual

3 zone extinguishing
control panel to protect 1 risk

ESS-RP1r
(Software version 3.x)



CONTENTS

1. Introduction	2
1.1 Manual Purpose	2
1.2 Before Installation	2
1.3 System Design and Planning	2
1.4. CE Marking.....	2
1.5. General.....	3
1.6 Release control panel main features	4
1.7 Cabling	8
2. CONNECTIONS AND WIRING	9
2.1 Release control panel board diagram	9
2.2 Detection zone wiring	11
2.3 Sounder circuit wiring	12
2.4 Connection to monitored inputs	12
2.5 Relay wiring.....	13
2.6 24Vdc supply wiring	14
2.7 Digital input	15
2.8 User Keyswitch (level 2).....	15
3. System operation	17
3.1 Release control panel operating modes:	17
3.2 Access levels	17
3.3 Normal condition	17
3.4 Single zone fire condition (Pre-activated)	18
3.5 Double zone alarm condition. (Activated)	18
3.6 Delay time before extinguishing release activation.....	19
3.7 Extinguishing release	19
3.8 Signal representing the flow of extinguishing agent	19
3.9 Low pressure signal	19
3.10 Open door signal.....	20
3.11 Hold device	20
3.12 Emergency Abort device	21
3.13 Manual release delay	19
3.14 End of extinguishing signal	21
3.15 Silence sounders.....	21
3.16 Sounder delay (Pre-activated status).....	22
3.17 Control of flooding time or soak time ("dr" parameter).....	23
3.18 Evacuate	23
3.19 Lamp test	24
3.20 Reset.....	24
3.21 Disable zones.....	24
3.22 Disable the extinguishing process	24
3.23 Monitored circuits faults	25
3.24 Activation of the Release 2 output	25
4. Programming mode	26
4.1 Microswitches configuration	29
5. Special functions	32
(EN54 non-compliance)	32

1. Introduction

1.1 Manual Purpose

The purpose of this manual is to provide the user with all recommended procedures and full technical details for the successful installation, commissioning and configuration of extinguishing control panel.

This manual must be read, and its contents clearly understood, before proceeding with any work relating to the control panel.

Damage to the control panel may result from NOT following the recommended procedures described in this manual. If there are any areas of doubt, consult your supplier before continuing with the system installation, commissioning and configuration.

1.2 Before Installation

The control panel is easy to install providing the recommended procedures described in this manual are followed.

Before working on mains connections, ensure main power supply to the panel is disconnected.

Read carefully the commissioning and configuration procedures of this manual. It is recommended by the manufacturer to check the wiring lines before making any connection to the panel or equipment. Do not carry out any configuration functions without fully understanding of their operation.

1.3 System Design and Planning

It is assumed that the system, of which this control panel is a part, has been designed by a competent fire alarm system designer in accordance with the requirements of EN54 Part 14 and any other local codes of practice that are applicable. The design drawings should clearly show the positions of the field devices and the control equipment.

In compliance with EN54-4/A2:2006, compulsory from August 2009, it is necessary to monitor the battery inner resistance to guarantee a safe and correct batteries performance in case of main power supply fault.

The control panel carries out measurements of battery resistance periodically to check the resistive value. If this value is higher than 700mohms, the control panel will report a power supply fault to indicate that the battery status is not correct.

Extinguishing control panels are manufactured in compliance with national and local standards. The control panel meets EN54-2 and EN-54-4/A2:2006 requirements.

However, some installation and configuration practices may contravene EN54 requirements. In this case, a suitable indication is given in the manual.

1.4. CE Marking

This panel is CE Marked to show that it conforms to the requirements of the following European Community Directives:

- Electromagnetic Compatibility Directive 89/336/EEC (and the amending Directives 92/31/EEC, 93/68/EEC)
- Low Voltage Directive 73/23/EEC (and the amending Directive 93/68/EEC).

1.5. General.

This release control panel has been designed to manage correctly and according to EN12094:1/2003 and EN54-2 and EN54-4/A2:2006 the automatic release sequence of any extinguishing system. This compact control panel has 2 microprocessors to increase safety and includes a switched 65W power supply with battery charger.

The control panel has 3 input zones for direct connection of 2-wire conventional detectors or external release call points. The control panel also includes two release monitored circuits and two sounder outputs with different frequencies in order to identify each release state (Pre-Activated Activated, Hold/Abort Condition and Imminent Release). At the front panel there are function pushbuttons, a release call point, a 2-digit countdown timer that indicates the seconds left for release activation (after release acknowledgement and with GAS sign on), and a keyswitch for operating mode selection: Automatic, Manual and Disabled.

There are a number of input circuits: Hold device, release abort device, low and flow pressure monitoring and open door monitoring, being able to cancel the extinguishing release. Apart from two release outputs there are also status outputs (Pre-activated, activated or extinguishing release in process), general fault, automatic release inhibited output and fault output in release circuit. The Release control panel also includes relay outputs in order to indicate the release status (automatic, manual or system disabled), whether the control panel is in hold or abort mode and the flow detector status and two more outputs for Resettable and non-resettable power supply.

The Release control panel allows the connection to a remote station and telephone communicator through Ademco Contact ID format. History log is included.

This control panel can be easily configured by means of built-in microswitches. Extinguishing delays can be programmed in five second steps from 0 to 60 seconds and 4 different soak delays can also be configured (at 2 seconds, 60 seconds, from 0 to 300 seconds or from 0 to RESET).

This extinguishing control panel has been designed in compliance with **EN12094:1 2003: Fixed fire fighting systems – Components for gas extinguishing systems** - Part 1: Requirements and test methods for electrical automatic control and delay devices.

Moreover, Release control panel meets the following EN12094:1 *Options with requirements*:

- 4.17 Delay of extinguishing signal.
- 4.18 Signal representing the flow of extinguishing agent.
- 4.19 Monitoring of the status of components. (Low/flow pressure)
- 4.20 Emergency hold device. (Sequence *b*)
- 4.21 Control of flooding time.
- 4.23 Manual only mode.
- 4.26 Triggering of equipment outside the system. (Required in Belgium).
- 4.27 Emergency abort device.
- 4.30 Activation of alarm devices with different signals.

NOTE: While every effort is made to ensure the accuracy of the content of this manual, the manufacturer reserves the right to change the information without notice.

1.6 Release control panel main features

- Compact control panel with double microprocessor.
- Supply Rating: 90-264Vac 50/60Hz. Total power: 65W (2,4A a 27Vcc). Maximum current supplied by Release control panel: 2,4Amp.
- 2 monitored sounder outputs (2 x 250mA)
- 2 auxiliary power supply outputs 2 x 250mA (non-resettable and resettable).
- 2 release circuits. Maximum current of each release circuit: 1Amp. (Remember that the max. current that the control panel can supply is 2,4Amp).
- Control panel quiescent current: 125mA.
- Battery charge current: 300mA maximum (7A/h batteries).
- Battery fuse: F4L 250V (4Amp).
- All the outputs have electronic fuses for short circuits protection.
- Panel sealing: IP30.
- History log of 450 events to be displayed by PK-RP1r.
- Climatic classification: Class A, indoor. Operating temperature: -5°C to +40°C. Humidity: 95% max. R.H.
- 2 conventional detection zones for detectors and 1 conventional detection zone for detectors or manual release.
- Extinguishing abort and hold devices.
- Programmable sounders delay (rS) before sounders activation from 1 to 10 min.
- Sounder delays override by keyboard, call point alarm or 2 zones in alarm.
- Input circuits for flow and low pressure, open door control and mechanical release disablement.
- 2 release circuits. The second release circuit can be used for preactivation, independently from zone prealarm/alarm and it also activates with Release Output 1 by default.
- Countdown timer indicating the seconds left to release.
- 36 indicator leds for quick identification of events.
- Relays:
 - General alarm (Pre-activation)
 - Extinguishing process activated (coincidence)
 - Evacuate
 - Extinguishing release in process
 - Release circuit fault
 - General fault
 - Flow pressure switch
 - Status:
 - Manual
 - Automatic
 - Release disabled.
- Open collector output to signal release in:
 - Hold mode
 - Abort mode
- Digital input for remote actions configurable as: system reset, Evacuate, silence or delay on/off.
- Plug-in terminals for all connections.
- Software to display the system status in a PC.
- Designed in compliance with EN54-2, EN54-4/A2:2006 and EN12094/1:2003.
- Dimensions (mm): 379 (width) x 356 (height) x 95 (depth).

ACCESSORIES

- **VSN-LL** Keyswitch for level 2 access.
 - **PK-RP1r** Monitoring software.
 - **VSN-232** RS-232 port card.
 - **VSN-IP** IP Address card (VSN-232 required).
 - **VSN-4REL** Four relay card.
-
- **DIMENSIONS (mm):** 379 (width) x 356 (height) x 95 (depth).

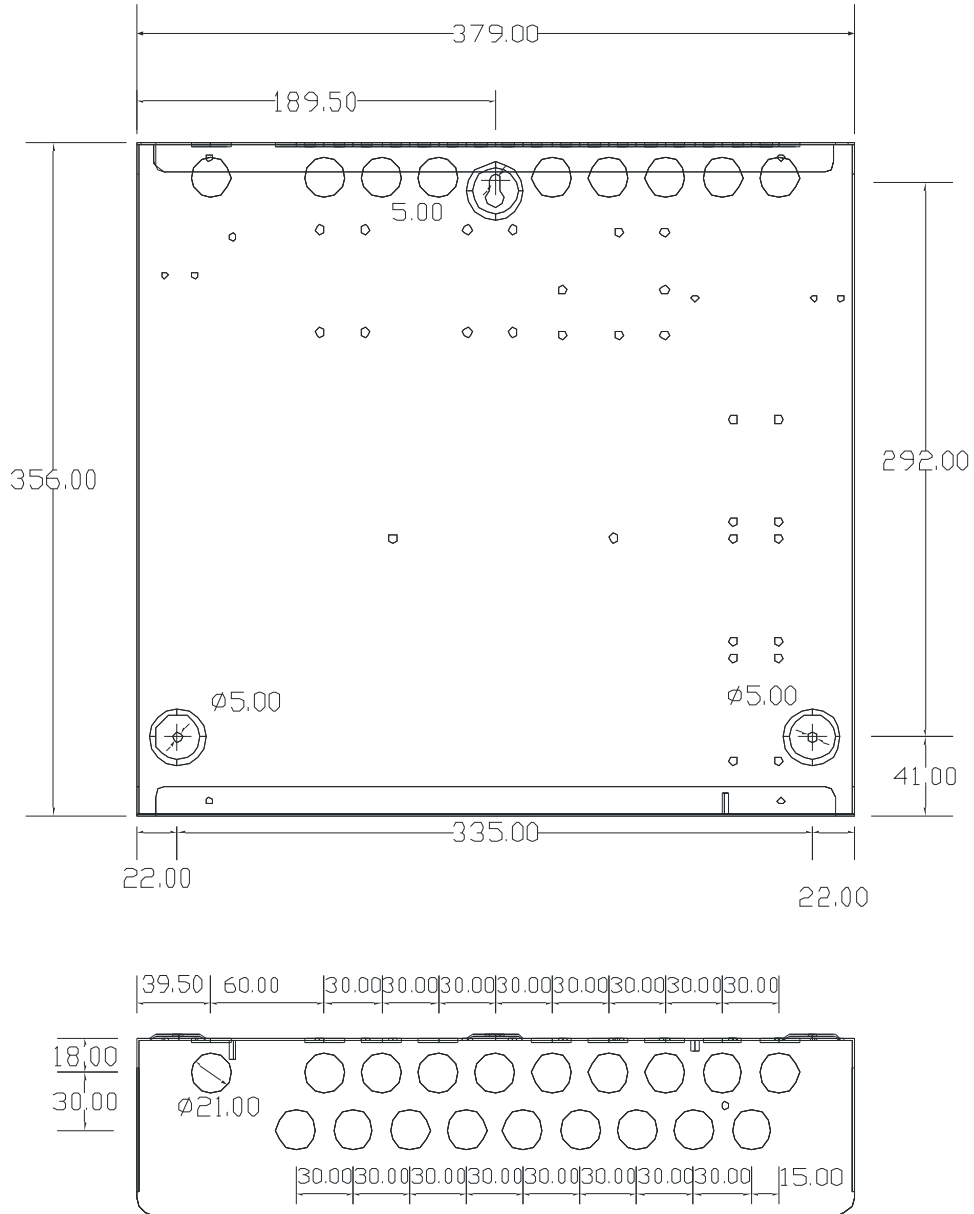

Front Panel Indications:

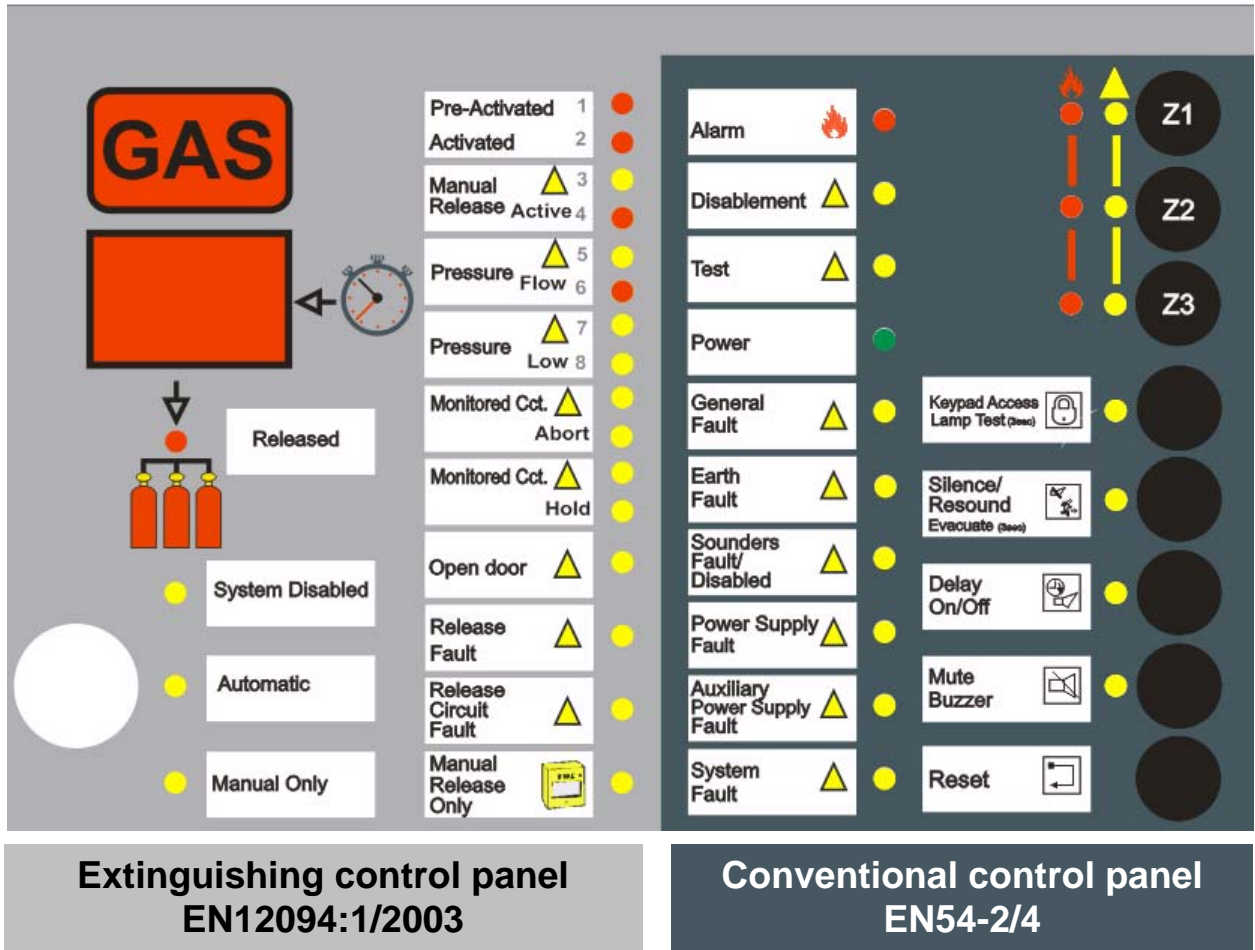

1.7 Cabling

Cabling Instructions

All wiring should comply with current IEE wiring regulations (BS7671) or the applicable local wiring regulations. Note also the requirements of EN54-14 for cabling and interconnection of a fire detection and alarm system.

EMC Requirements: To meet the EMC requirements of the European Directives, it is necessary to ensure that a screened or metal sheathed cable is used.

Cable conductor size should be a minimum of 0.5mm². Terminals accept one 0.5 to 2.5mm² stranded or solid conductor.

Cables should be brought into the back box through the 20mm knockouts provided on the top face and base. Ensure that all openings in the back box are closed off before connecting power to the panel.

Mains Supply

The supply to the panel must be provided with a suitable and readily-accessible, double-pole, **mains-disconnect device**. The mains supply must be suitably fused and rated according to the specifications.

Always ensure that the mains cables are brought into the back box separately to the low-voltage wiring. All low-voltage cables should have a minimum 300Vac rating.

The termination of earth mains wiring must be done before the termination of any external cable screens.

Cable Screen Wires

Cables should be screened. Screen wires should be terminated inside the back box as follows:

- a. Screen tails should be of sufficient length to connect to the earth post at the commissioning stage. Once all screen wires have been terminated, ensure that a good earthing bond is created.
- b. Use insulation sleeving on the tails between the cable entry position and the earth post. Run the tails close to the rear wall of the back box.

Cable Terminations

This section provides guidance on where to bring cables into the back box for ease of termination.

- a. The mains supply should be brought into the control panel such that the live (L) and neutral (N) cable path to the mains termination block is kept as short as possible. This must be done before terminating all other panel wiring.
- b. All zone and ancillary cable terminations should be brought into the panel at suitable positions and routed tidily between entry and termination points.

Quality of Cable and of Cable Installation

It is important that good quality cable is used, and that correct installation techniques are followed. In general, the following cable installation requirements must be met:

- a. All cable sections must be circular to allow effective cable clamping using the cable glands.
- b. The cable must be screened (sheathed) to provide protection against Radio Frequency Interference (RFI) and the screen must be connected to the earthing point in the back box
- c. The screen must be continuous.
- d. Cable recommended for use is MICC with a LSF PVC overcovering, a fire resilient cable to BS7629 or PVC/SWA/PVC to BS6387.

Recommended Cables

Recommended cables for this panel are as follows:

Manufacturer	Product Name	Part Number	Type ⁽¹⁾
AEI	MICC	2L1.5	Enhanced
AEI	Firetec	298-052	Standard
Draka	FiretufPlus	FTPLUS2E1.5RD	Enhanced
Draka	Firetuf	FTZ 2E1.5	Standard
Pirelli	FP Plus	FP Plus 2x1.5 Red	Enhanced
Pirelli	FP200 Gold	FP200 Gold 2x1.5 Red	Standard
ASCABLE	2 x 1,5 LHR	2 x 1,5 LHR	Fire resistant and halogen free
ASCABLE	2 x 2,5 LHR	2 x 2,5 LHR	Fire resistant and halogen free

(1) For a definition of 'Standard' and 'Enhanced' cable requirements and their different applications, refer to BS 5839-1, Section 26. Enhanced cable is typically required for spur sounder outputs while standard cables may be adequate for other fire-related I/O, provided there is diverse cable routing.

Main Zones

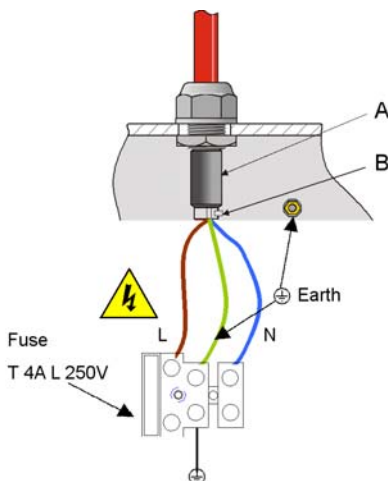
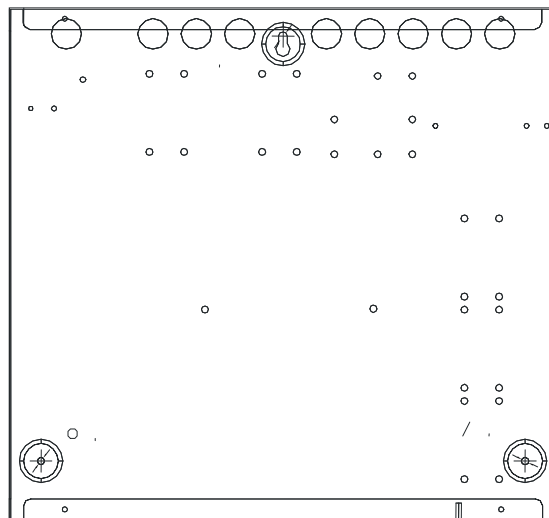
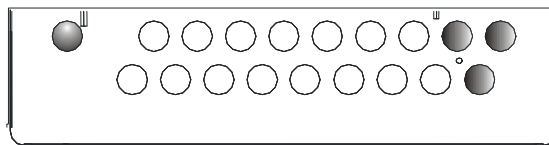

EMC Considerations

Following the above instructions and by using suitable screened cables EMC problems will be avoided.

In particularly difficult EMC environments, or where non-preferred cabling is used, it is possible to fit ferrite sleeves to cables entering the panel, in particular the power supply input, sounder and auxiliary output cables.

The ferrite sleeves (A) should be fitted over all the conductor(s) and as close as possible to the entry point of the cable. If required, use a cable tie (B) - not supplied - to hold the ferrite in position.

If additional ferrites are required these can be purchased from your supplier.

2. CONNECTIONS AND WIRING

2.1 Release control panel board diagram

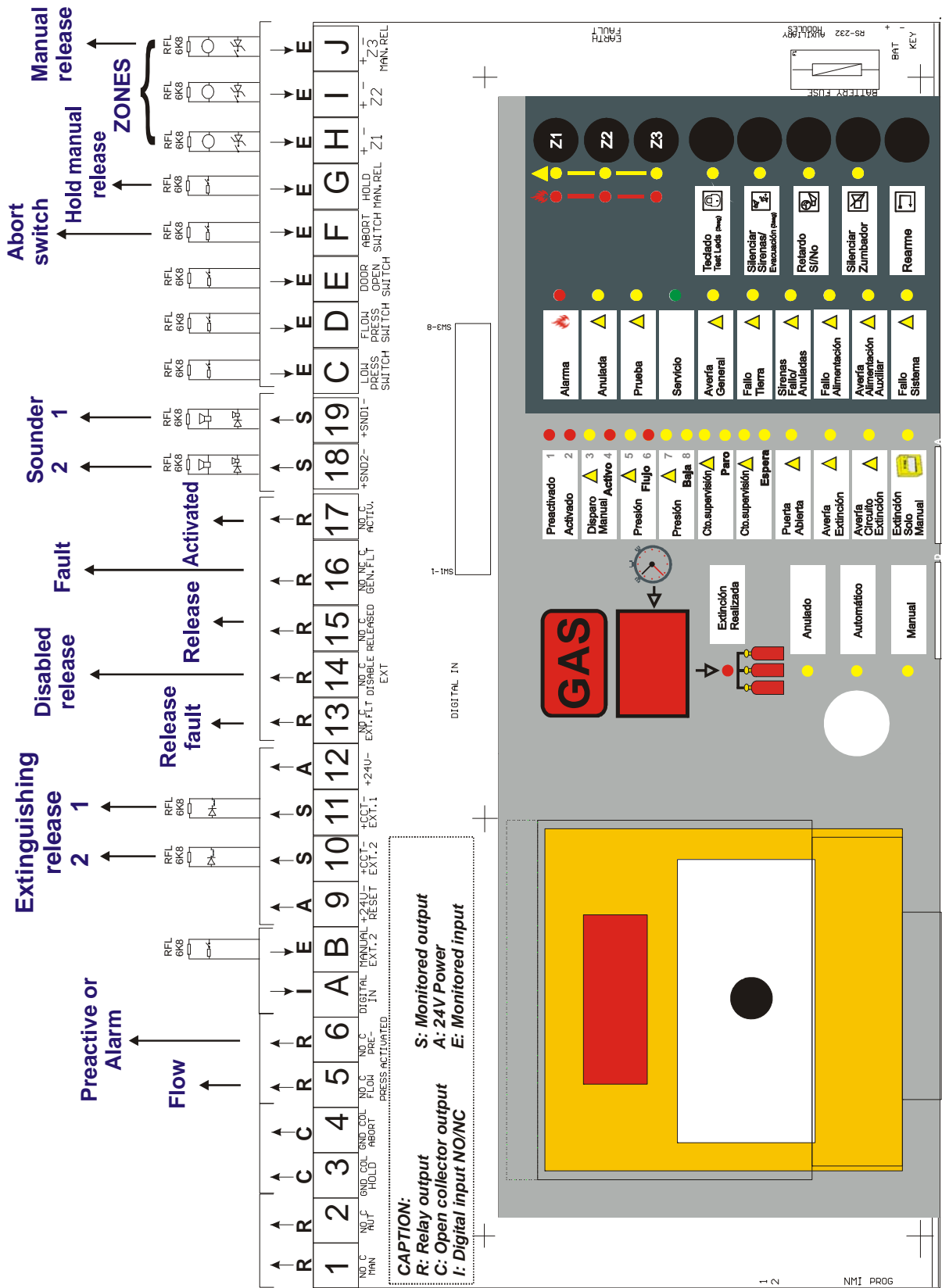

Note: Relays 1, 2, 5, 6, 13, 14, 15 and 17 are NO (Normally Open) but can become NC (normally closed). Contact with Honeywell Life Safety Iberia Technical Department.
 Relay 16 (fault) is NO/NC (Normally Open / Normally Closed)

VSN-4REL and VSN-232 connections

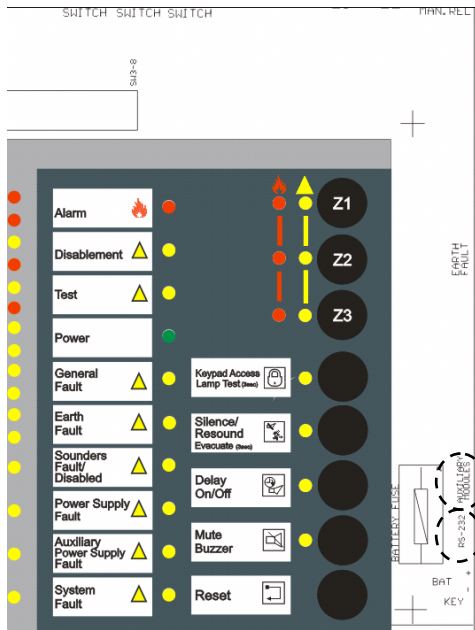

VSN4-REL FUNCTIONS

Relay 1	Fire Zone 1
Relay 2	Fire Zone 2
Relay 3	Fire Zone 3
Relay 4	Preactivation or Activation

2.2 Detection zone wiring. Terminal blocks: H (Z1), I (Z2) y J (Z3)

The detection zones provide a nominal 24Vdc to power conventional detectors and call points.

Detection zone circuits must be wired as a single circuit with no spurs or T junctions to enable the monitoring circuit to work correctly.

When using Notifier series 800 or Morley ECO1000 detectors, up to 32 detectors can be installed.

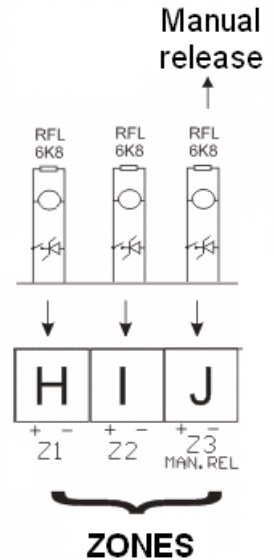
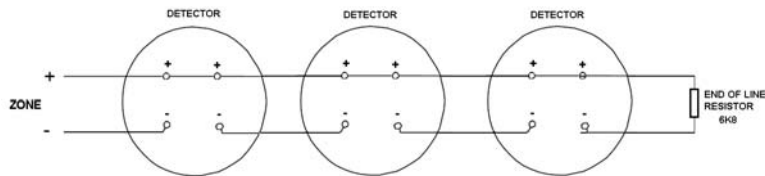

2.2.b. ZONE 1 AND 2 WIRING WITH MCP OR ZONE 3 AS GAS RELEASE CALL POINT (SW1-5 OFF)

When it is necessary to distinguish between the indication of a detector alarm and a call point alarm in the zone, a 5V1 Zener must be installed in Zones 1 and 2.

The detector alarm will be indicated by the led in flashing mode and the call point alarm will be indicated by the led in steady mode.

If Zone 3 is set as Manual Release zone (SW1-5 in OFF position) it is not necessary to install a 5.1Vdc Zener to indicate the call point alarms.

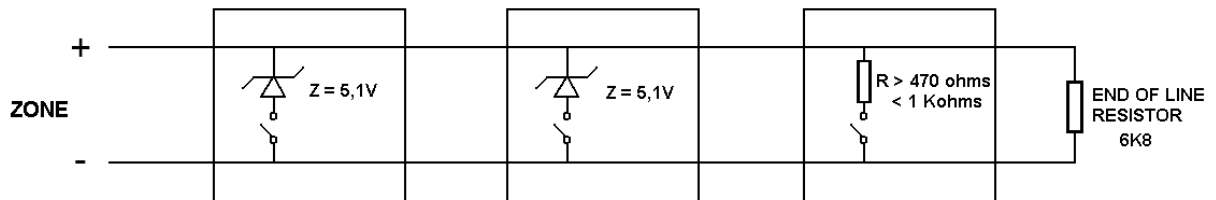

Zone status according to power ratings:

%	0	15	27	74	94	100			
Description	Short circuit		Call point alarm		Detector alarm	Normal Status 6K8	Open circuit		
Volts	4		7	18	23	25			
Resistor	0	50	100	150	200	1K2	1K5	6K8	10K

(Approximate values)

2.3 Sounder circuit wiring. Terminal blocks: 18 and 19

All sounders must be of the polarised type. In non-polarised sounders are used, the control panel will permanently show a fault condition, and therefore, a polarisation diode should be installed in the sounder.

Sounder circuits must be wired as a single circuit with no spurs or T junctions to enable the monitoring circuit to work correctly.

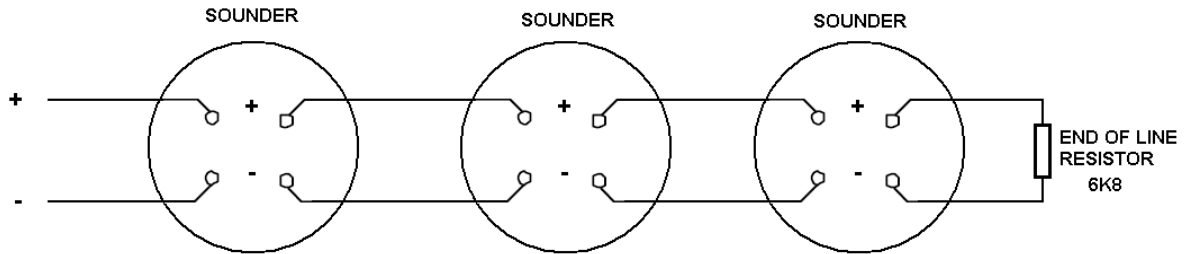

NOTE: The above drawing shows the polarity when sounders are activated. When sounders are in stand-by, the sounder polarity is reversed.

2.4 Connection to monitored inputs

By default, all monitored inputs are Normally Open (NO) contacts and they are activated when the circuit is closed with a 2K2 resistor.

Normally Open Circuit (NO)

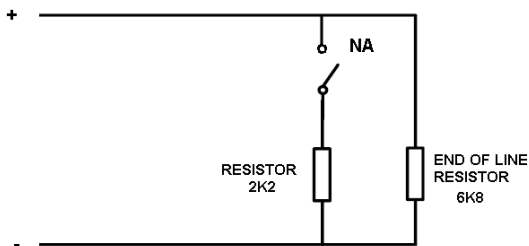

Normally Closed Circuit (NC)

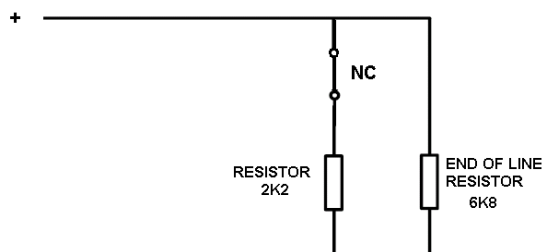

%	0	15	26	40	80	100				
Description	NO	Short circuit	Activation NO 2K2//6K8	Activation NO without EOL 2K2	Normal Status 6K8	Open circuit				
Description	NC	Short circuit	Normal Status 2K2//6K8	Only 2K2	Only 6K8	Open circuit				
Resistor	0	680	1K	1K5	2K	3K	4K7	6K8	8K	> 10K

(Approximate values)

Important note:

In Normally Open (NO) circuits, when the R=2K2 line is closed, the input becomes ACTIVE, even if the EOL resistor (6k8) is not detected. In this case (ACTIVE input with EOL resistor not detected), a fault will also be indicated.

In Normally Closed (NC) circuits, when the R=2K2 line is open, the input becomes ACTIVE, even if the EOL resistor (6k8) is not detected. In this case (ACTIVE input with EOL resistor not detected), a fault will also be detected.

2.5 Relay wiring. Terminal blocks: 1, 2, 5, 6, 13, 14, 15 and 17

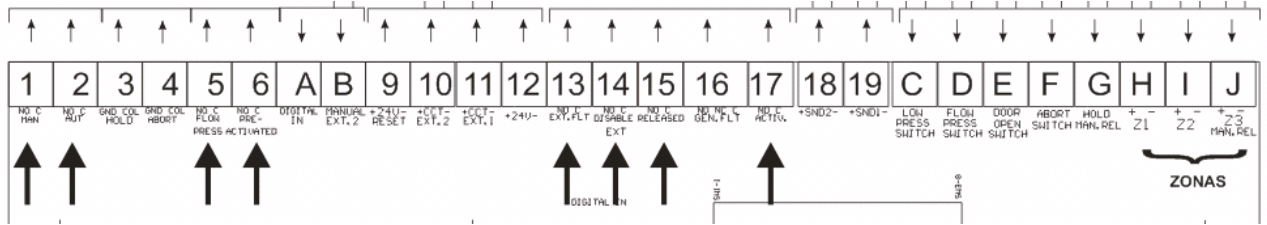

Wiring suitable for the following relays (see drawing on the right):

- General alarm (preactivation)
- Release process activation (coincidence)
- Evacuate,
- Release in process
- Release circuit fault
- Flow pressure switch
- Status:
 - Manual
 - Automatic and
 - System disabled.

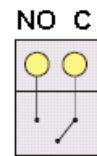

Fault relay wiring. Terminal blocks: 16

The fault relay is activated in stand-by status and deactivated when there is a fault in the control panel or when the control panel power is switched off. Faults can be configured as resettable or latched. Faults are latched by default and the panel has to be reset for the relay to return to stand-by. On the contrary, the resettable faults make the relay return to stand-by automatically, when the fault disappears.

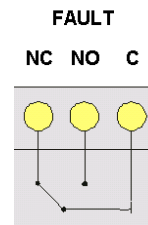

Open collector outputs. Terminal blocks: 3 and 4

- The open collector output indicates the release in:
 - Hold Mode
 - Abort Mode

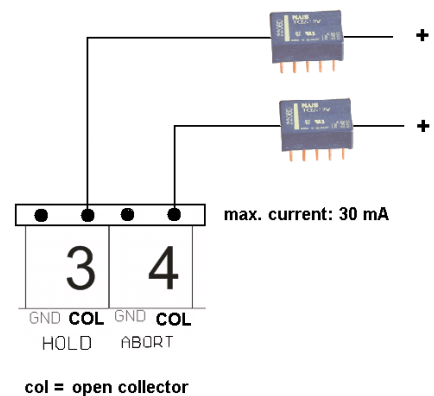

2.6 24Vdc supply wiring. Terminal blocks: 9 and 12

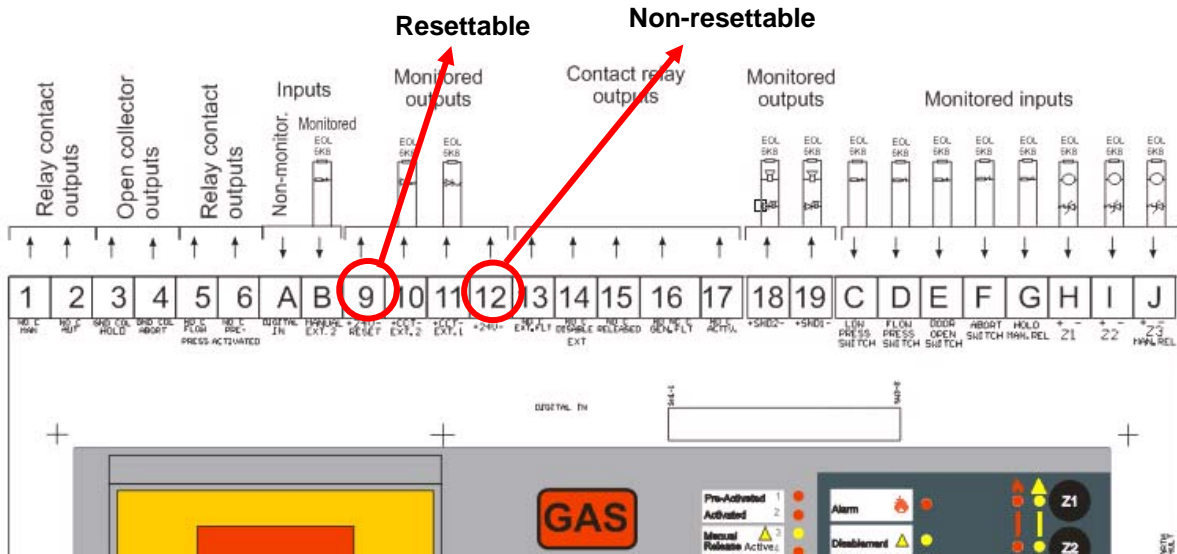

The Release control panel has two 24Vdc outputs, supplied by the control panel power supply.

The maximum current between both outputs is 500mA, protected with electronic fuse.

Aux 24V fixed voltage output provides constant 24V and a maximum current of 250mA to supply auxiliary devices.

Res 24V resettable voltage output and 250mA provides resettable supply. The voltage goes down to 0V for 5 seconds, each time the control panel is reset. This output is used to supply power to external devices that need to switch off the power supply in order to be reset.

Before connecting external devices to the control panel, please check the current that they require.

Bear in mind the power usage of the system in alarm and stand-by. Make sure that the control panel power supply and battery have enough capacity, otherwise use suitable external power supply units. In order to calculate the power consumption, please refer to the technical specifications of this manual and of the devices to be connected.

To connect holder coils, relays or valves, refer to the diagram below. Make the connections as indicated in the drawing; otherwise the control panel may be damaged.

2.6 b Solenoid wiring (the following drawing shows the polarity when the system is activated)

Terminal blocks: 10 and 11

Different options depending on the solenoid:

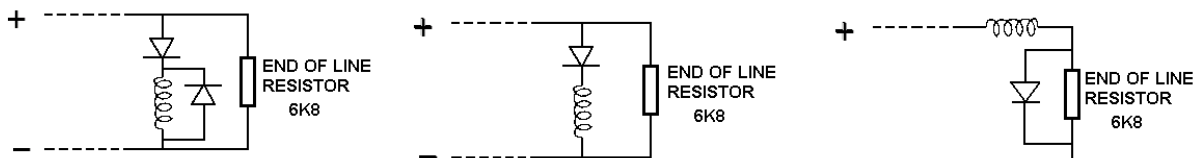

- **Note:** The polarity shown in the above drawing is the corresponding to the ACTIVATE status of Ext 1 and Ext 2 outputs (10 and 11 in the Release control panel board). When the system is in stand-by, the polarity is reversed. The maximum current per release circuit is 1Amp. (Remember that the max. Current supplied by the control panel power supply is 2.4Amp).

2.7 Digital input. Terminal blocks: A

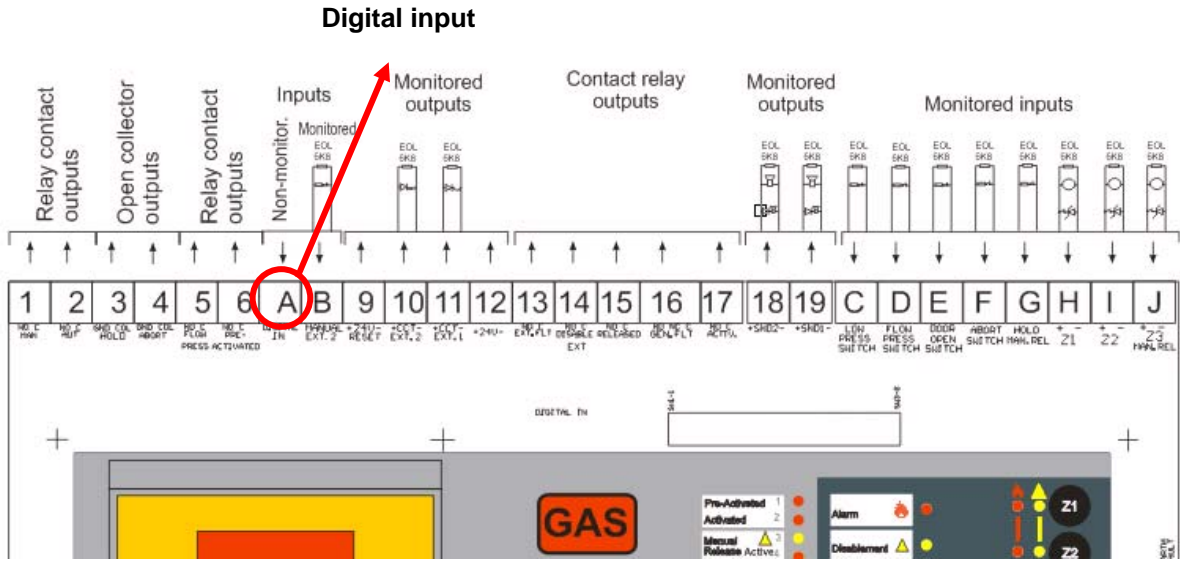

The control panel has a digital input for external configurable contact in order to control the panel from any other external system.

By using a button or a NO or NC external contact (potential free contacts), depending on the configuration, the following functions can be operated: RESET, EVACUATE, MUTE SOUNDERS/BUZZER, DELAY ON/OFF, MUTE BUZZER.

!Do not use live contacts in the digital input or the control panel will be irreversibly damaged!

2.8 User Keyswitch (level 2)

The Release control panel has a switch to connect the optional keyswitch (not included) in order to make the level 2 access easier, without a password.

Keyswitch can be supplied separately with a terminal switch to be connected to the control panel board.

The access is made when the keyswitch contact is closed. The control panel remains at Level 2 (user functions) until the keyswitch changes its position.

Alternatively, Level 2 may be accessed by means of a password. Refer to the operating sections of this manual.

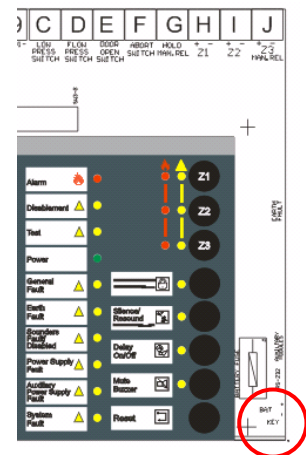

Keyswitch installation

Replace the front cover label with the one supplied with the keyswitch.

To fit the key, remove nuts and washers from the cylinder lock and introduce the cylinder with cables into the keyswitch hole (A) from the outside of the cover.

Keep the cylinder lock in its position, completely fitted into the hole (A) and fit washers and nuts from the inside of the cover, through the cable up to their position in the cylinder. Tighten with a proper wrench until the cylinder cannot be moved.

Connect the cable to the switch (B) and close the cover carefully making sure that the cables do not get caught. Finally, fit the cover to the rear box with mounting screws.

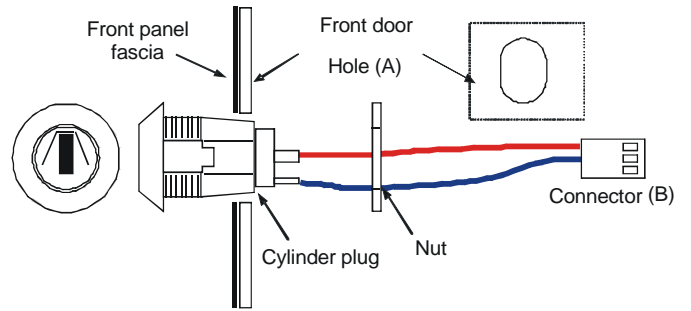

3. System operation

3.1 Release control panel operating modes:

- **Automatic:**
 - The control panel manages any alarm from zones or from the gas release call point on the front panel and carries out the release process automatically following the conditions and delays already configured.
- **Manual only:**
 - The control panel manages any alarm from zones, activating the corresponding conditions and sounders. However, the release can only be activated from the GAS release call point located on the front panel or from the Zone 3 (it is configured as Manual Release).
- **System disabled:**
 - The same as the above condition but it does NOT allow the release outputs to be activated, even manually.

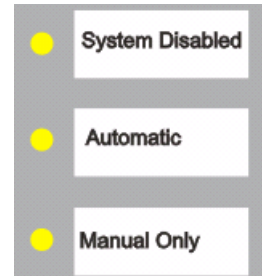

3.2 Access levels

- **Level 1:**
 - It is always accessible and allows access only to MUTE BUZZER.
- **Level 2:**
 - Keypad Access led ON. It is accessible by using the optional keyswitch VSN-LL or by holding the **Keypad Access** key pressed while pressing the following key sequence: **Z1, Z2, Z2** and **Z1**. After pressing these keys, the led of Keypad Access will be ON and the control panel and zone keys will become enabled. If any function or zone key is pressed without having access to level 2, control panel buzzer will be activated briefly together with the keypad access led.
- **Level 3:**
 - It allows access to the configuration options by enabling the PROG switch located in the left bottom corner of the Release control panel board.

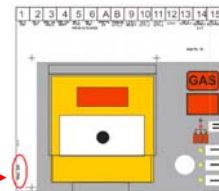
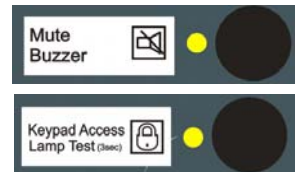

3.3 Normal condition

Under normal conditions, the control panel has only lit the green **Power** LED and the **Automatic** LED.

Under normal conditions, without faults, the fault relay (GEN.FLT) is energized, in stand-by, with continuity between fault relay Closed (C) and Normally Open (NO) terminals. This relay changes its status if the control panel is not powered or under a fault condition.

Access level 1 only enables the MUTE BUZZER key and the rest of function keys are enabled with access level 2, by means of an access code or using the optional keyswitch.

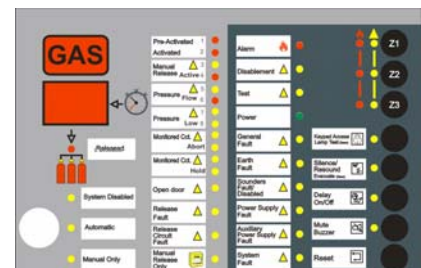

3.4 Single zone fire condition (Pre-activated)

By default, the control panel activates the extinguishing release process when there is an alarm in Zone 1 and Zone 2. In this case, the control panel will activate the following:

- Control panel inner buzzer.
- Alarm led in flashing mode at 1 Hz.
- Alarm zone led. Steady led if the alarm comes from a zone call point (5.1Vdc Zener) or Flashing led at 1Hz if the alarm comes from a detector.
- Sounder 1 and 2 at 1Hz if there are no delays. Slow frequency.
- Pre-activated led (Extinguishing release in pre-activated mode).
- Pre-activated relay.

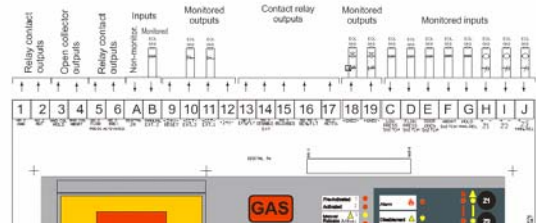

3.5 Double zone alarm condition. (Activated)

Upon activation of a second alarm zone or the gas release call point (automatic or manual), the control panel goes from Pre-activated mode to Activated mode and will activate the following:

- Inner buzzer.
- Alarm led in steady mode.
- New alarm zone led: Steady led if the alarm comes from a zone call point (5.1Vdc Zener) or flashing led at 1Hz if the alarm comes from a detector.
- Sounder 1 and 2 at 2Hz if there are no delays. Rapid frequency.
- Activated led (Extinguishing release in activated mode).
- Activated relay.

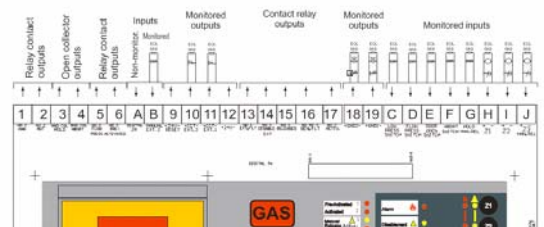

Moreover, the release sequence starts:

- The countdown begins. By default, the timer shows 60 seconds.
- The GAS sign flashes.

3.6 Delay time before extinguishing release activation

The section 4.17: Delay of extinguishing signal of EN12094:1/2003 specifies a delay known as a pre-discharge-warning time that shall be adjustable from 00 and 60 seconds in steps of maximum 5 seconds.

This delay time is restricted to the access level 3 and will be indicated at access level 3 in the field Delay (dL).

The Release control panel has 7 preset values based on the SW3-3, 4, 5 switches position:

SW3-3, 4, 5			Delay (dL)
000	=	OFF OFF OFF	Adjustable from 00 to 60 seconds
001	=	OFF OFF ON	5 seconds
010	=	OFF ON OFF	10 seconds
011	=	OFF ON ON	15 seconds
100	=	ON OFF OFF	30 seconds
101	=	ON OFF ON	45 seconds
110	=	ON ON OFF	60 seconds
111	=	ON ON ON	0 seconds

0= OFF; 1=ON

NOTE: During the delay time, the sounders cannot be silent.

3.7 Extinguishing release

When the time delay is over, the control panel activates the following:

- Two solenoid circuits for the time configured in “dr” parameter.
- Status of relay “Released”.
- Gas sign in steady mode.
- Timer indicating 00 seconds in flashing mode.
- Steady buzzer.
- Flashing “Released” led.

3.8 Signal representing the flow of extinguishing agent

The control panel has a flow pressure input, according to Section 4.18 of EN12094:1/2003. When the self-resetting flow pressure input activates, the following outputs will be activated:

- Steady inner buzzer.
- Steady sounders 1 and 2.
- FLOW PRESSURE relay output.
- Activated led.
- Activated relay.

3.9 Low pressure signal

Low pressure input (*low press*) indicates the condition of extinguishing agent loss. This fault will activate the buzzer, the low pressure signal, the fault led and the fault relay.

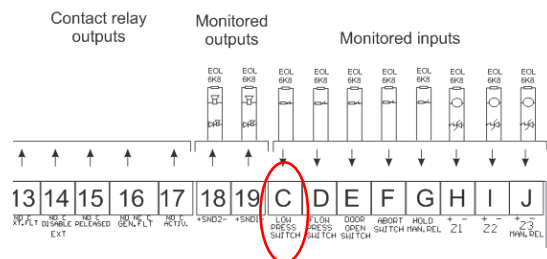

3.10 Open door signal

This input indicates the state of the control panel door. This information may be useful before the user presses the manual release call point on the control panel. This indication is just to provide information, but by means of SW2-5 switch, the automatic gas release can be blocked if the door is open.

When the SW2-5 switch is in ON position (and consequently the gas release is blocked), each time the open door input is activated, the following outputs will also be activated provided that the control panel is in extinguishing status:

- Control panel buzzer.
- General fault led.
- General fault relay.
- Open door signal.
- Hold mode signal.
- Hold relay activated.

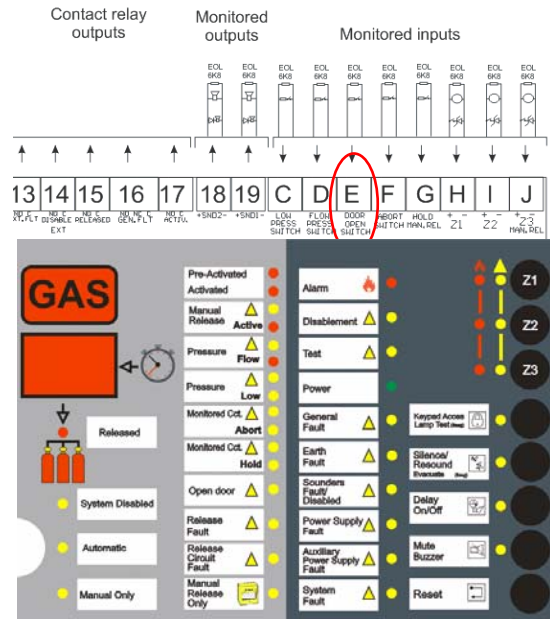

If the countdown is activated (release in process) and the door is open (with SW2-5 in ON position), the release process goes into Hold mode. When the door is closed, the countdown starts again from the value configured in dL function.

If the open door signal is activated but the control panel is not in release status, only the Open Door led will be lit.

NOTE: If the **option 4.26 from EN12094:1/2003** norm (see page 30) is enabled, then the Open Door led will be used to show if the fan output is disabled (led ON) or enabled (led OFF). In that case, the Open Door input signal will be indicated in the 7-segment display, where "od" means Open Door activation and "." means Open Door circuit fault.

3.11 Hold device

This control panel meets the requirements of EN12094-1/2003 Section 4.20 b) Emergency hold device (Option with requirements).

The hold call point (HOLD MRL) can cancel the automatic extinguishing status. When this call point is activated (G), the open collector output HOLD (3) is activated and the timer stops. This input is self-resettable. When the call point is pressed, the countdown timer stops and when the call point is released, the countdown starts again.

If the hold call point is activated when the control panel has already started the countdown (Activated mode), the control panel sounders will change from rapid frequency (2Hz) mode to low frequency mode (0,5Hz).

According to EN12094:1/2003 Section 4.20.4, when there is a fault in the monitoring circuit of the hold/abort device, the control panel must indicate a fault and prevent the transmission of the extinguishing signal.

When such a fault occurs in the Release control panel, apart from indicating the fault, the HOLD relay is also activated.

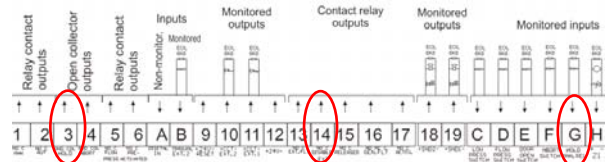

Using the SW1-7 switch, the hold device can be configured to have priority over this input. If the hold input must have priority over gas release call point (the one located on the control panel or the one installed in Zone 3), the SW1-7 must be in ON position.

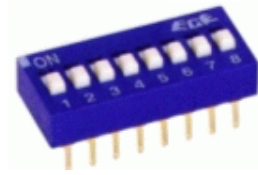

When the control panel is in hold mode, the Disable extinguishing relay (14) will be activated.

3.12 Emergency Abort device

According to EN12094:1/2003 Section 4.27, if the emergency abort input is activated, the extinguishing signal shall be inhibited.

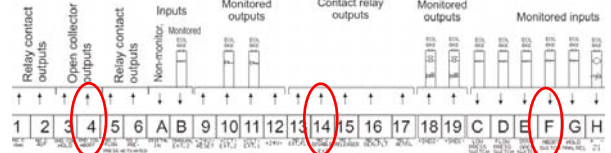

Release control panel meets this requirement: the abort call point cancels the extinguishing status. Moreover, this abort input is latched and it will be necessary to do a manual reset in order to activate again the extinguishing process.

When this input is activated (F), the open collector output Hold/abort (4) and the Disable extinguishing relay (14) are also activated.

3.13 Manual release delay

The manual release call point located at the front panel can be activated when the control panel is in *Automatic* or *Manual Only* mode. When the control panel is in *System Disabled* mode, the manual release activation only generates a Pre-Activated condition (sounders activation).

When the SW2-7 microswitch is in OFF position (by default), there is a delay, from the call point activation until the release activation, determined by the **dL** function (60 seconds by default). In order to reduce this period of time to 3 seconds, the SW2-7 should be placed to the ON position (Refer to Section 4.1 Microswitches configuration).

3.14 End of extinguishing signal

When the extinguishing signal time (adjusted in the “d” function (soak time)) has finished, the following changes will take place:

- The two solenoid circuits will be deactivated
- Timer 00 in steady mode
- “Released” led in steady mode

3.15 Silence sounders

The sounders are silenced by pressing the **Silence/Resound** key if access level 2 is enabled. In order to enter access level 2, use the keyswitch or enable the keypad (see Section 3.2: Access levels).

When sounders are ON, they are silenced or reactivated by pressing the **Silence/Resound** key.

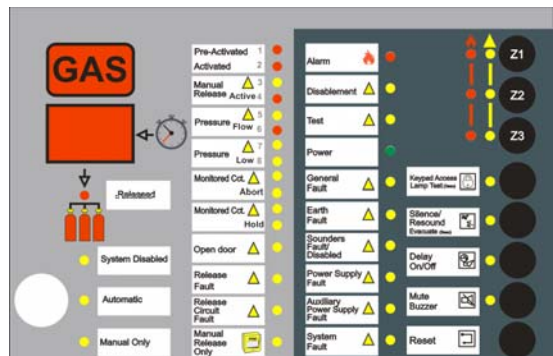

NOTE: The sounders may not be silent if the control panel is in extinguishing process.

3.16 Sounder delay (Pre-activated status)

NOTE: In order to enter programme mode, open the front door of the control panel, and connect a jumper between both terminals of PROG connector (see drawing below). The control panel display will show “S1”. Then, press *Keypad Access* key to scroll through the different functions (S1, S2, S3...) until the display shows **rS** (sounders’ delay).

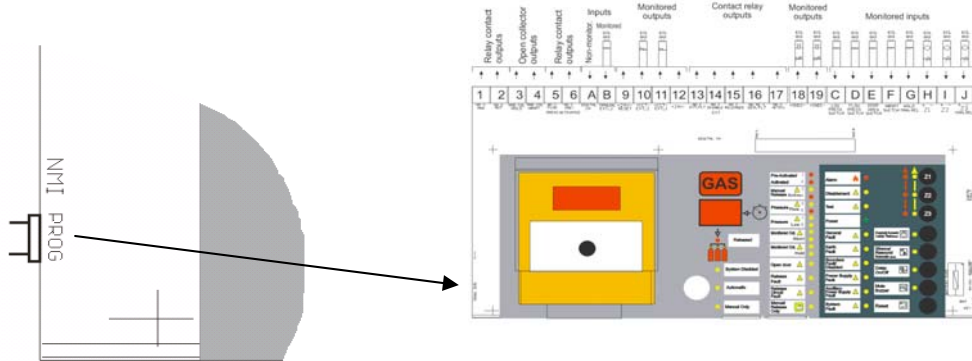

Sounders activation can be delayed in order to provide time for inspection and to silence sounders. When a second alarm occurs, sounders will activate immediately. That means that the sounder delay is only valid for the first alarm and is completely independent from the release delay.

There are two types of delay:

Sounders Fault/Disabled LED

When any of the two sounder circuits have not the EOL resistor installed, the sounders Fault/Disabled LED will be flashing at 2Hz (rapid frequency) indicating this condition. Moreover, the general fault led and the general fault relay will be also activated.

According to EN54, if the sounder activation is delayed, this “disabled” condition must be indicated. In order to meet this requirement, the Release control panel will activate the **Disablement** and the **Sounders Fault/Disabled** leds. In this case the leds will be flashing at slow frequency (1 Hz).

The **Delay On/Off LED** will be activated in flashing mode when the sounders are not activated yet due to any delay configured in rS (sounders’ delay) function.

How to disable the external equipment

When the option 4.26 of EN12094:1/2003 is enabled (see page 33), the external equipment may be enabled/disabled by pressing the Delay On/Off key for 3 seconds.

When the external equipment is disabled, the relay 4, located in the VSN-4REL board, will not activate in preactivated or activated condition and the *Dis. Ext. Equi* led in the front panel will be lit in steady mode.





Note: Be sure to use the label designed for option 4.26 on the right hand of page 34.

rS. Sounders' Delay. Period of time between the Mute buzzer key is pressed and the sounders activate. If a single zone alarm is activated, this period of time is used to check the alarm and reset the control panel before the sounders activate. If, during this period of time, the Delay On/Off key is pressed, the sounders will be activated (slow frequency) or deactivated by means of the Silence/Resound key.

The time options for the Sounders delay (rS) are the following, in seconds:

00 – 01 – 02 – 03 – 04 – 05 – 06 – 07 – 08 – 09 - 10

→  Press the **Delay On/Off** key to scroll through the values.

←  Press the **Mute Buzzer** key to move back.

↓  Press The **Keypad Access** key to go to the next function (EF):

If, in Pre-activated mode, the sounders are delayed because a delay has been configured, the control panel will indicate that the sounders are delayed and the Delay On/Off will be activated in flashing mode. During this period of time, sounders will be silenced by pressing the Silence/Resound key and the delay will be cancelled by pressing Delay On/Off, which will activate the sounders.

When the sounder delay has finished and the sounders are activated, the Delay On/Off key will no longer be in flashing mode and will be switched off.

In order to cancel the delay, just press the Delay On/Off key at any time. If the Delay On/Off led is lit, it means that the configured delays are disabled and, therefore, the sounders will activate immediately after any pre-activated condition starts.

3.17 Control of flooding time or soak time (“dr” parameter)

EN12094:1 Section 4.21 specifies a flooding time (up to at least 300s seconds) for low pressure CO₂ systems.

Release control panel allows the configuration of some flooding time intervals:

By default, the flooding time is set at 60 seconds but the control panel has other preset values selectable by means of SW3-6, 7 switches:

SW3-6 and SW3-7		Flooding time
00	= OFF OFF	60 seconds
01	= OFF ON	2 seconds (Pyrotechnic)
10	= ON OFF	Until the control panel is reset
11	= ON ON	Configurable from 00 to 295 seconds

0=OFF; 1=ON

3.18 Evacuate

In order to activate the sounders in flashing mode (at 2Hz, rapid frequency), press the **Silence/Resound/Evacuate** key for 3 seconds.

The alarm led will be also lit to indicate that a manual evacuate command has been given.



Note 1: The evacuate function is only available at access level 2.

Nota 2: Solenoid outputs will not be activated.

3.19 Lamp test

Press the **Keypad Access / Lamp Test** key for 3 seconds to test the leds. Keypad must be enabled (access level 2). With this function, all the leds and the inner buzzer will be tested automatically.



3.20 Reset

To reset the control panel, enable access level 2 and press the **Reset** key. Latched inputs will be reset.

According to EN12094:1 Section 4.12.2, the reset function may be inhibited after starting the Activated condition in access level 3.

To enable the Reset function, place the SW1-6 microswitch in ON position. The 7 segment display will show S1, which means that the SW1 configuration has been changed. Then, connect a jumper in **PROG** switch located in the left bottom corner of the Release control panel board and press the **Reset** key. Consequently, the number 6 led will be activated in red and steady mode.

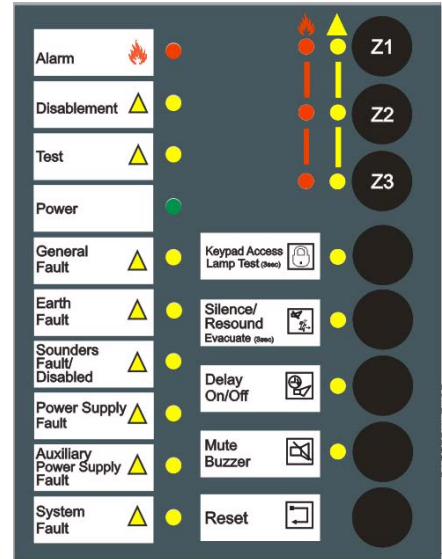
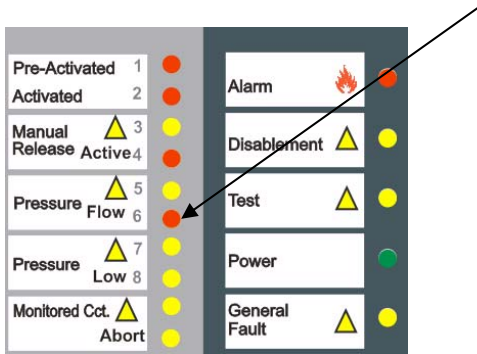

3.21 Disable zones

To disable any of the 3 detection zones from the access level 2, press the zone key pushbutton required. The Zone led (Z1, Z2 or Z3) will be lit in yellow and the Disablement led will also be activated in yellow.



3.22 Disable the extinguishing process / sounders

To disable the extinguishing process, place the keyswitch in the System Disabled position. Then, the whole manual or automatic release process will be disabled and the Disable relay will be activated.

How to disable the sounders

According to EN12094-1:2003 part 4.15 "Disabling of the transmission path to the alarm devices of a flooding zone shall be possible only in combination with the disabling of the transmission path to the actuators of the total flooding zone".

So the sounders only will be disabled when the panel is in Disabled mode. To disable/enable sounders, press the Silence/Resound Key in access level 2.

NOTE: The sounder circuits will be enabled automatically when the panel changes to Automatic or Manual Only mode.

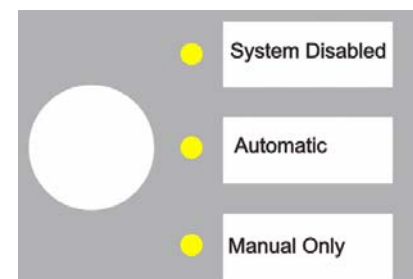

3.23 Monitored circuits faults

All the monitored inputs and outputs require a 6K8 EOL (end of line) resistor in order to check the wiring. If there is a short circuit or the control panel does not detect the EOL resistor (open circuit), the control panel will indicate a fault by activating the circuit led in flashing mode, the fault relay and the general fault relay.

Cct.	Description	LED	Notes
10	CCT EXT 2	Flashing release circuit fault	Automatic reset
11	CCT EXT 1	Flashing release circuit fault	Automatic reset
18	SND 2	Flashing Sounders fault/disabled	Automatic reset
19	SND 1	Flashing Sounders fault/disabled	Automatic reset
C	LOW PRESS	Flashing Low Pressure fault	Automatic reset
D	FLOW PRESS	Flashing Flow Pressure fault	Automatic reset
E	DOOR OPEN	Flashing Open door	Automatic reset
F	ABORT SWITCH	<ul style="list-style-type: none"> Flashing abort fault Steady abort 	This fault that requires a manual reset cancels the release process.
G	HOLD SWITCH	<ul style="list-style-type: none"> Flashing hold fault Steady hold 	Automatic reset
H	ZONE 1	Zone 1 in flashing fault	Automatic reset
I	ZONE 2	Zone 2 in flashing fault	Automatic reset
J	ZONE 3	<ul style="list-style-type: none"> Zone 3 in flashing fault and Flashing Manual release fault (SW1-5 OFF) 	Automatic reset. If SW1-5=OFF, therefore Zone 3 is used as Manual Release, when there is a fault condition, the Manual Release led will also be activated in yellow.

3.24 Activation of the Release 2 output

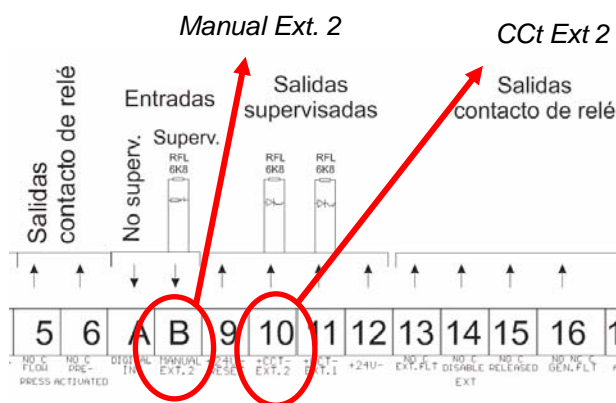

When the **SW1-8** switch is in the **ON** position, the *Ext. 2* output can be activated independently (see 10 in the drawing), by means of the *Manual Ext 2 input* (B).

When this input is activated, and therefore *Ext.2* output is also activated, the following will occur:



- The inner buzzer will be activated.
- The Manual release led will be activated in flashing mode.
- The fault led and relay will be activated and,
- The control panel display will show **E2**.

In order to turn off the Manual release and Fault leds, it is necessary to reset the control panel.

4. Programming mode

By connecting a jumper in PROG switch located in the left button corner of the Release control panel board (access level 3) the following options, indicated in the table below will be accessible.

- Press the **Keypad Access** key to scroll through the different options.
- Press the **Reset** key to accept a new value or change the S1, S2 and S3 microswitches.
- Press the **Delay On/Off** to increase a value.
- Press the **Mute Buzzer** key to decrease a value.

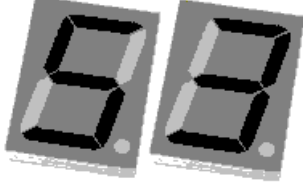
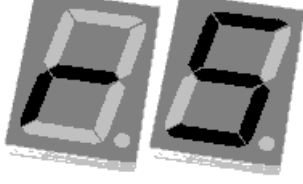
<p>S1</p> 	<p>This parameter indicates the SW1 microswitches status. When a DIP switch is in ON position, the relevant led (one of the 8 indicated below) will be activated in steady mode. When the position of a DIP changes, the relevant led will be activated in flashing mode and the new configuration will need to be accepted by pressing the Reset key.</p> <table border="1" data-bbox="528 779 735 1055"> <tbody> <tr> <td>Pre-Activated</td> <td>1</td> <td>●</td> </tr> <tr> <td>Activated</td> <td>2</td> <td>●</td> </tr> <tr> <td>Manual Release Active</td> <td>3</td> <td>▲</td> </tr> <tr> <td></td> <td>4</td> <td>●</td> </tr> <tr> <td>Pressure Flow</td> <td>5</td> <td>▲</td> </tr> <tr> <td></td> <td>6</td> <td>●</td> </tr> <tr> <td>Pressure Low</td> <td>7</td> <td>▲</td> </tr> <tr> <td></td> <td>8</td> <td>●</td> </tr> </tbody> </table>	Pre-Activated	1	●	Activated	2	●	Manual Release Active	3	▲		4	●	Pressure Flow	5	▲		6	●	Pressure Low	7	▲		8	●
Pre-Activated	1	●																							
Activated	2	●																							
Manual Release Active	3	▲																							
	4	●																							
Pressure Flow	5	▲																							
	6	●																							
Pressure Low	7	▲																							
	8	●																							
<p>S2</p> 	<p>This parameter indicates the SW2 microswitches status. When a DIP is in ON position, the relevant led (one of the 8 indicated above) will be activated in steady mode. When a DIP is in OFF position, the led is switched off. When the position of a DIP has been changed, the led is in flashing mode. The new configuration must be accepted by pressing the Reset key.</p>																								
<p>S3</p> 	<p>This parameter indicates the SW3 microswitches status. When a DIP is in ON position, the relevant led (one of the 8 indicated above) will be activated in steady mode. When a DIP is in OFF position, the led is switched off. When the position of a DIP has been changed, the led is in flashing mode. The new configuration must be accepted by pressing the Reset key.</p>																								
<p>rS</p> 	<p><u>Sounders' delay.</u> This is a delay time between 00 and 10 minutes, which is applied after the Mute Buzzer key is pressed in order to verify the alarm condition, before the sounders are activated. (Default value: 00 min.)¹.</p>																								

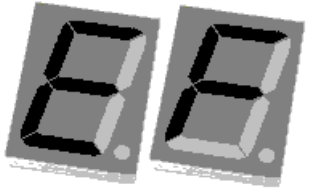
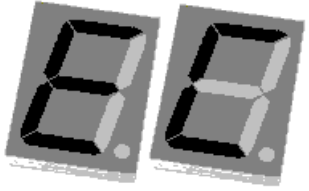
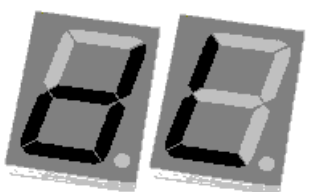
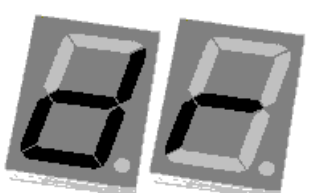
<p>EF</p> 	<p>This parameter allows the selection of the Digital input function:</p> <p>0 = Remote reset (<i>by default</i>)¹ 1 = Evacuate 2 = Silence sounders 3 = Delays On/Off 4 = Mute buzzer</p>																		
<p>EC</p> 	<p>This parameter has two configuration options:</p> <p>0 = The digital input is activated when the Normally Closed contact is open. 1 = The digital input is activated when the Normally Open contact is closed (<i>by default</i>)¹.</p>																		
<p>dL</p> 	<p><u>Extinguishing release delay.</u> This parameter has 7 preconfigured values depending on the SW3-3,4,5 position. When SW3-3, SW3-4 y SW3-5 are in OFF position, the delay can be configured, from 00 to 60 sec, using the keyboard keys (see the previous page).</p> <table border="1" data-bbox="646 913 1444 1205"> <thead> <tr> <th>SW3-3, 4, 5</th> <th>Delay (dL)</th> </tr> </thead> <tbody> <tr> <td>000</td> <td>Configurable from 00 to 60 sec. (<i>By default</i>)¹</td> </tr> <tr> <td>001</td> <td>5 seconds</td> </tr> <tr> <td>010</td> <td>10 seconds</td> </tr> <tr> <td>011</td> <td>15 seconds</td> </tr> <tr> <td>100</td> <td>30 seconds</td> </tr> <tr> <td>101</td> <td>45 seconds</td> </tr> <tr> <td>110</td> <td>60 seconds</td> </tr> <tr> <td>111</td> <td>0 seconds</td> </tr> </tbody> </table> <p>0 = OFF ; 1 = ON</p>	SW3-3, 4, 5	Delay (dL)	000	Configurable from 00 to 60 sec. (<i>By default</i>) ¹	001	5 seconds	010	10 seconds	011	15 seconds	100	30 seconds	101	45 seconds	110	60 seconds	111	0 seconds
SW3-3, 4, 5	Delay (dL)																		
000	Configurable from 00 to 60 sec. (<i>By default</i>) ¹																		
001	5 seconds																		
010	10 seconds																		
011	15 seconds																		
100	30 seconds																		
101	45 seconds																		
110	60 seconds																		
111	0 seconds																		
<p>dr</p> 	<p><u>Soak time:</u> This parameter is only configurable if SW3-6 and SW3-7 are in ON position (1). Otherwise, the value displayed in this field is only for information.</p> <table border="1" data-bbox="689 1400 1444 1563"> <thead> <tr> <th>SW3-6 y SW3-7</th> <th>Soak time</th> </tr> </thead> <tbody> <tr> <td>00</td> <td>60 seconds (<i>By default</i>)¹</td> </tr> <tr> <td>01</td> <td>2 seconds (Pyrotechnic)</td> </tr> <tr> <td>10</td> <td>Until the control panel is reset</td> </tr> <tr> <td>11</td> <td>Configurable from 00 to 295 seconds</td> </tr> </tbody> </table> <p>0 = OFF ; 1 = ON</p>	SW3-6 y SW3-7	Soak time	00	60 seconds (<i>By default</i>) ¹	01	2 seconds (Pyrotechnic)	10	Until the control panel is reset	11	Configurable from 00 to 295 seconds								
SW3-6 y SW3-7	Soak time																		
00	60 seconds (<i>By default</i>) ¹																		
01	2 seconds (Pyrotechnic)																		
10	Until the control panel is reset																		
11	Configurable from 00 to 295 seconds																		

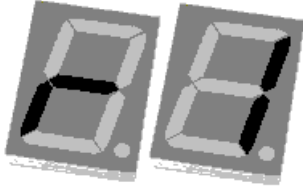
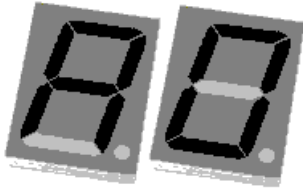
<p>r1</p> 	<p>Reset inhibited. According to EN12094:1/2003 Section 4.12.2, there must be a programmable time period up to 30 minutes, from when the control panel signals the ACTIVATED status until the RESET function is enabled. By default, the Release control panel has this function disabled (SW1-6 in OFF position). In order to enable it, the SW1-6 must be placed in ON position and this new configuration must be accepted by pressing the Reset key. Then, inside programming mode, when the r1 parameter is displayed, the <i>Delay On/Off</i> key or the <i>Mute Buzzer</i> key must be pressed to increase or decrease the period of time required to inhibit the reset function (up to 30 minutes). With this function enabled, the control panel reset will be allowed only after finishing the period of time configured. <i>By default: 00 minutes</i>¹ NOTE: When the control panel is in Abort/Hold mode, the reset function is available.</p>
<p>A0</p> 	<p>Delayed sounders indication. According to EN54-2: 9.4.2c, the sounders delay must be indicated as a disconnection. Thus, if the sounders activation is delayed, the (rS) delay values will be other than 00 and, therefore, the Disablement led will be activated in steady mode and the Sounders fault/disabled led will be activated in flashing mode. This parameter (A0) shows the configuration of the sounders delay: If A0 = 0 (<i>default</i>¹). Any delay for the sounders activation will be indicated by the Disablement led and the Sounders fault/disabled led in yellow and steady mode, which means that rS values are other than 00. If A0 = 01 and there is no delay configured for the sounders activation, the Disablement led and the Sounders fault/disabled led will not be activated.</p>

Note 1: In order to restore the default configuration, connect a jumper in the **PROG switch** located in the left bottom corner of the control panel board. Then, while keeping the **Keypad Access** key pressed, press the following sequence of keys: **Z1+Z2+Z2+Z1**.

4.1 Microswitches configuration

Micro-switch (SW)	Function
SW1-1	OFF: A short circuit in any zone is indicated as a fault. ON: A short circuit in any zone is indicated as an alarm.
SW1-2	OFF: Low pressure input is activated by a short circuit (R2K2). See the drawing below. ON: Low pressure input is activated by an open circuit (6K8).
SW1-3	Cross zone options:
SW1-4	OFF OFF Z1 AND Z2 OR Z3 OFF ON Z1 OR Z2 OR Z3 ON OFF (Z1 AND Z3) OR (Z2 AND Z3) OR (Z1 AND Z2) Only if Z3 is a detector zone SW5=ON ON ON Z1 AND Z2 AND Z3 Only if Z3 is a detector zone SW5=ON
SW1-5	OFF: Zone 3 is configured as a Gas release call point. ON: Zone 3 is a conventional detector zone
SW1-6	OFF: A reset can be done in any moment. ON: Depending on the value configured in "rl" parameter, as indicated in EN 2094:1/2003 Section 4.12.2
SW1-7	OFF: HOLD MAN. REL input has NO priority over the Gas release call point. ON: HOLD input HAS priority over the Gas release call point.
SW1-8	OFF: MANUAL EXT.2 (manual release) input is DISABLED. EXT.2 (release output 2) is activated like EXT 1 output but is NOT activated by the MANUAL EXT. 2 input. ON: MANUAL EXT.2 is ENABLED. If MANUAL EXT.2 is activated, the EXT 2 output will also activated.

Normally Open Circuit (NO)

Normally Closed Circuit (NC)

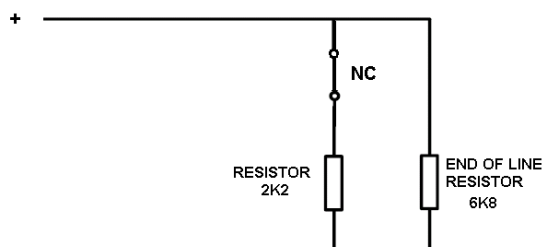
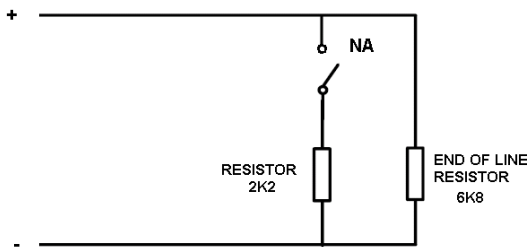

%	0	15	26	40	80	100				
Description	NO	Short circuit	Activation NO 2K2//6K8	Activation NO without EOL 2K2	Normal Status 6K8	Open circuit				
Description	NC	Short circuit	Normal Status 2K2//6K8	Only 2K2	Only 6K8	Open circuit				
Resistor	0	680	1K	1K5	2K	3K	4K7	6K8	8K	> 10K

(Approximate values)

Important note:

In Normally Open (NO) circuits, when the R=2K2 line is closed, the input becomes ACTIVE, even if the EOL resistor (6K8) is not detected. In this case (ACTIVE input with EOL resistor not detected), a fault will also be indicated.

In Normally Closed (NC) circuits, when the R=2K2 line is open, the input becomes ACTIVE, even if the EOL resistor (6K8) is not detected. In this case (ACTIVE input with EOL resistor not detected), a fault will also be detected.

Micro-switch (SW)	Function
SW2-1	OFF: HOLD and ABORT inputs are activated by short circuit (R=2K2). ON: HOLD and ABORT inputs are activated by open circuit (6K8). See previous page.
SW2-2	OFF: FLOW input is activated by short circuit (R=2k2). ON: FLOW input is activated by open circuit (6K8). See previous page.
SW2-3	OFF: DOOR OPEN input is activated by short circuit (R=2k2). ON: DOOR OPEN input is activated by open circuit (6K8). See previous page.
SW2-4	<i>Released</i> indicator LED. OFF: The Release activation is indicated when the period of time configured in the dr parameter (Soak time) expires. ON: Release activation is indicated when the LOW PRESSURE input is activated.
SW2-5	OFF: DOOR OPEN input only for information. ON: DOOR OPEN input to cancel temporarily the extinguishing release until the door is closed. Unlike the HOLD switch, this input does not activate the buzzer when the control panel is in normal or pre-activated status. The open door input activates the buzzer just when the control panel is in activated status, during the countdown (if SW2-5 = ON).
SW2-6	OFF: Sounders are activated in Prealarm or Pre-activated status. ON: Sounders are activated just in Alarm or Activated status. NOTE: If the option 4.26 from EN12094:1/2003 norm (see page 30) is enabled (see page 30), the position of the SW2-6 microswitch will have another function: OFF: the 4 th relay will be switched on in the VSN-REL in case of preactivated condition. ON: the 4 th relay will be switched on in case of activated condition.
SW2-7	OFF: Manual release (activated by gas release call point on the control panel or Zone 3), with the same delay than the automatic zones (this delay time is configured in dL parameter). ON: Output activation delay of 3 seconds.
SW2-8	OFF: Zones with manual activation. ON: Zones with alarm verification. Conventional zones may need to be verified. If SW2-8 = ON, when an alarm is activated in one zone, the zone is automatically reset by the control panel waiting for the alarm to be confirmed, in the next 10 minutes. If a new alarm is activated in any zone, the alarm is indicated immediately. Otherwise, the verification timer will be restarted after 10 minutes.

Micro-switch (SW)	Function																											
SW3-1	<p>OFF: Sounder 2 operates, by default, like sounder 1 (flashing mode) and its frequency depends on the control panel status. See sections 3.4 and 3.5.</p> <p>ON: Sounder 2 is always activated in steady mode.</p>																											
SW3-2	<p>The FLOW input can be used to check that the extinguishing release is in process.</p> <p>OFF: FLOW input is not used for subsequent release activations.</p> <p>ON: FLOW input activates for some impulses of release outputs. If they are not confirmed through flow input, a release fault condition will be indicated.</p>																											
SW3-3 SW3-4 SW3-5	<p>These 3 microswitches indicate the delay time from when an alarm is confirmed (ACTIVATED status) until the release circuit is activated.</p> <p>000= Time dL (<u>Extinguishing release delay</u>) will be 60 seconds by default.</p> <table border="1" style="margin-left: 40px;"> <thead> <tr> <th colspan="2">SW3-3, 4, 5</th> <th>Extinguishing release delay (dL)</th> </tr> </thead> <tbody> <tr> <td>000</td> <td>= OFF OFF OFF</td> <td>Configurable from 00 to 60 seconds</td> </tr> <tr> <td>001</td> <td>= OFF OFF ON</td> <td>5 seconds</td> </tr> <tr> <td>010</td> <td>= OFF ON OFF</td> <td>10 seconds</td> </tr> <tr> <td>011</td> <td>= OFF ON ON</td> <td>15 seconds</td> </tr> <tr> <td>100</td> <td>= ON OFF OFF</td> <td>30 seconds</td> </tr> <tr> <td>101</td> <td>= ON OFF ON</td> <td>45 seconds</td> </tr> <tr> <td>110</td> <td>= ON ON OFF</td> <td>60 seconds</td> </tr> <tr> <td>111</td> <td>= ON ON ON</td> <td>0 seconds</td> </tr> </tbody> </table> <p>0= OFF; 1=ON</p>	SW3-3, 4, 5		Extinguishing release delay (dL)	000	= OFF OFF OFF	Configurable from 00 to 60 seconds	001	= OFF OFF ON	5 seconds	010	= OFF ON OFF	10 seconds	011	= OFF ON ON	15 seconds	100	= ON OFF OFF	30 seconds	101	= ON OFF ON	45 seconds	110	= ON ON OFF	60 seconds	111	= ON ON ON	0 seconds
SW3-3, 4, 5		Extinguishing release delay (dL)																										
000	= OFF OFF OFF	Configurable from 00 to 60 seconds																										
001	= OFF OFF ON	5 seconds																										
010	= OFF ON OFF	10 seconds																										
011	= OFF ON ON	15 seconds																										
100	= ON OFF OFF	30 seconds																										
101	= ON OFF ON	45 seconds																										
110	= ON ON OFF	60 seconds																										
111	= ON ON ON	0 seconds																										
SW3-6 SW3-7	<p>Length of time to dump release agents when a releasing zone activates (soak time)</p> <table border="1" style="margin-left: 40px;"> <thead> <tr> <th colspan="2">SW3-6 y SW3-7</th> <th>Soak time</th> </tr> </thead> <tbody> <tr> <td>00</td> <td>= OFF OFF</td> <td>60 seconds</td> </tr> <tr> <td>01</td> <td>= OFF ON</td> <td>2 seconds (Pyrotechnic)</td> </tr> <tr> <td>10</td> <td>= ON OFF</td> <td>Until the control panel is reset</td> </tr> <tr> <td>11</td> <td>= ON ON</td> <td>Configurable from 00 to 295 seconds</td> </tr> </tbody> </table> <p>0=OFF; 1=ON</p>	SW3-6 y SW3-7		Soak time	00	= OFF OFF	60 seconds	01	= OFF ON	2 seconds (Pyrotechnic)	10	= ON OFF	Until the control panel is reset	11	= ON ON	Configurable from 00 to 295 seconds												
SW3-6 y SW3-7		Soak time																										
00	= OFF OFF	60 seconds																										
01	= OFF ON	2 seconds (Pyrotechnic)																										
10	= ON OFF	Until the control panel is reset																										
11	= ON ON	Configurable from 00 to 295 seconds																										
SW3-8	<p>ON: Used to control the extinguishing process of the release outputs (1 and 2) with the Hold/Abort input. When the release is in process, if the Hold/Abort input is activated, the release is cancelled while the release input is still activated. The release status is indicated by means of the <i>Released</i> led.</p> <p>OFF: When the release output is activated, the Hold/Abort input will not cancel the release.</p>																											

5. Special functions (EN54 non-compliance)

Special configuration for sites which do not meet EN54 requirements.

Release control panel allows special configurations for resettable faults, single 24V operation for naval sites or powered from UPS, or single 220Vac operation as a dependant subsystem. These configurations do not meet EN54-2 and EN54-4/A2:2006 requirements and are only used for special operations.

It is highly recommended not to modify the default configuration of these options because the system may no work properly and will not comply with EN54-2 and EN54-4/A2:2006.

These options must not be modified without previous permission form the competent authority for naval sites or integrated subsystems, for which these special options have been included in the Release control panel.

Switch off the control panel completely (main power supply and batteries). Then power again the control panel and all the leds will be momentarily activated followed by the special function leds.

Press the following keyswitches to toggle between ON and OFF for each led. The led status will indicate the function enabled, as follows:

Keypad Access	=ON = Latched faults. Faults need to be RESET by the control panel (by default). =OFF= Resettable faults. Faults are self-resettables once the fault cause has disappeared.
Silence/Resound	=ON = Main power supply faults are indicated (by default) =OFF = Main power supply faults are not indicated.
Delay On/Off	=ON = Battery faults are indicated (by default) =OFF = Battery faults are not indicated.
Mute Buzzer	=ON = Sounders will resound after a new alarm (by default) =OFF = Sounder will not resound after a new alarm
Led Zone 1	=ON = 1 VSN4-REL installed =OFF = No VSN4-REL installed
Led Zone 2	=ON = Option 4.26 from EN12094:1/2003 enabled (Belgium requirement) =OFF = Option 4.26 from EN12094:1/2003 not enabled (other countries)

Special configuration:

Do not carry out any special configuration in the system without prior authorization.

In order to modify special functions:

- i) Switch off the control panel (main supply and batteries).
- ii) Switch on the panel while pressing the special function key required until all leds are lit. Then, special function leds will be lit to indicate the status of the current configuration.

ESSER

by Honeywell

Honeywell Life Safety Iberia

Delegación Este: Avda. Conflent 84, Nave 23. Pol. Ind. Pomar de Dalt. 08916 Badalona BARCELONA

Tel. : 93 497 39 60 Fax: 93 465 86 35

Delegación Centro: Avda. Severo Ochoa, 39 Local C PAE Casablanca II 28100 Alcobendas MADRID. Tel. 911314800 Fax 911314899

Delegación Sur: C/ Comercio, 51 2ª Pl. Edif. Hermes II Pol. Ind. PISA 41927 Mairena SEVILLA Tel 95/4187011 Fax 95/5601234

Delegación Norte: C/ Artatza, 7 bajos, Edificio Gobelas. 48940 Leioa - BIZKAIA Tel.: 944802625 Fax: 944801756

Delegación Portugal: Rua Neves Ferreira, 12-A; 1170-274 Lisboa PORTUGAL Tel.: 00 351 21 816 26 36 Fax: 00 351 21 816 26 37

www.esser.es